

# eco•tainer

## “TRI-CART”

### C. F. MAIER CONTAINER SYSTEM



Designed to meet today's  
Recycling applications.

The key to successful recycling is  
Convenience and attractiveness.



Expand your recycling program with our *eco•tainer* in areas where  
wheeled carts are used.

This colored, weather resistant, fiberglass reinforced enclosure holds  
3 individual wheeled universal carts of almost all brand name sizes  
up to 105 gallon capacity.

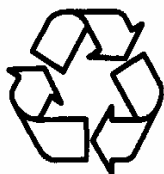

Manufacturers of Custom Made Fiberglass Parts for Over 39 Years World Wide.

# eco•tainer “TRI-CART”

## STANDARD FEATURES:

- eco•tainer is made of high strength fiberglass reinforced composites.
- Weather resistant coat of standard earth tan colored gelcoat.
- Door panel and closing mechanisms are mounted on a durable, special coated steel frame.
- 80” aluminum piano door hinge for easy access and long lasting performance.
- Two heavy duty zinc plated telescopic door props for easy access that provide support for hands free insertion or removal of carts.
- eco•tainer is equipped with locks and carriage key to secure container door.
- 3 drop-in holes for recyclables are standard and cut to your specification.
- 3 material decals (of our standard selection) are standard.

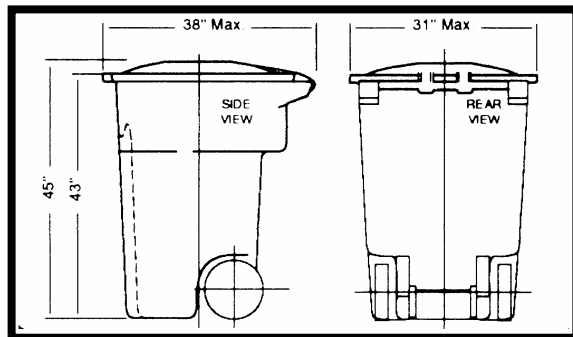

Largest cart dimensions to fit in *eco•tainer Tri-Cart* – 45" maximum height and 31" maximum width per cart.

**Carts not included.**

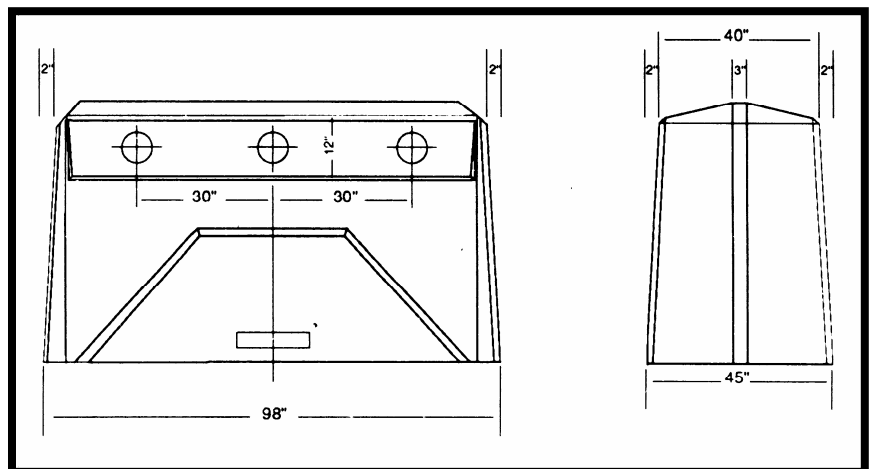

Outside dimensions of *eco•tainer Tri-Cart*