

eco•comb 400

The Container for Professionals C. F. Maier Recycling Systems

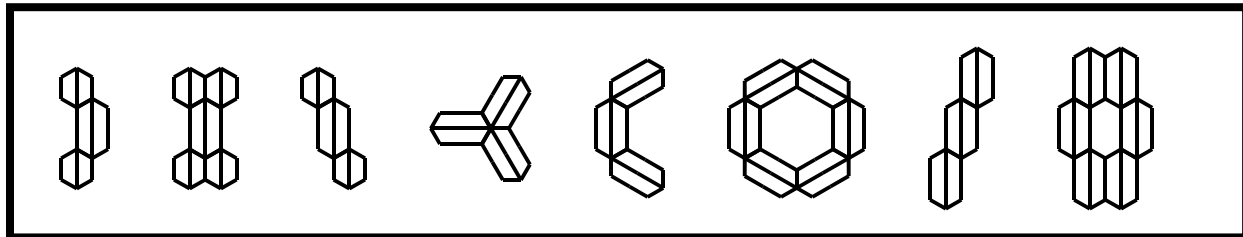

Set up combinations of eco•comb 400's mixed with eco•comb 800's

The *eco•comb 400* is our original *eco•comb* model. The 400's capacity is approximately 400 gallons. Their honeycomb design allows for many space saving set-up combinations using the *eco•comb 400* alone or in combination with the *eco•comb 800*.

Like all other *eco•comb* containers, the 400's discharge mechanism is designed around the outside of the container for unobstructed discharge and free-flow of all materials. Discharge is controlled with a variable opening control mechanism and equipped with outside hinged bottom doors.

The *eco•comb 400* is delivered fully assembled and ready for use.

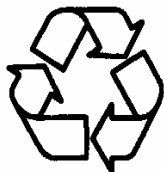

Practical



Economical



Attractive



eco•comb 400

Built to Handle Your Needs

Standard Features

- Approximate capacity of 400 gallons.
- The container is built of high impact fiberglass reinforced composites.
- Weather resistant coat of standard earth-tan colored gelcoat.
- All stress zone areas on container are reinforced with extra high strength materials.
- Exposed metal fittings are all zinc-plated metal, or aluminum.
- Containers are resistant to extreme high and low temperatures.
- The eco•comb 400 is efficient for the collection of all types of materials.
- Containers for paper collection have fire retardant coating applied to interior.
- Models for paper collection are equipped with spreader-bar mechanisms to allow for unobstructed and free flow when discharging material.

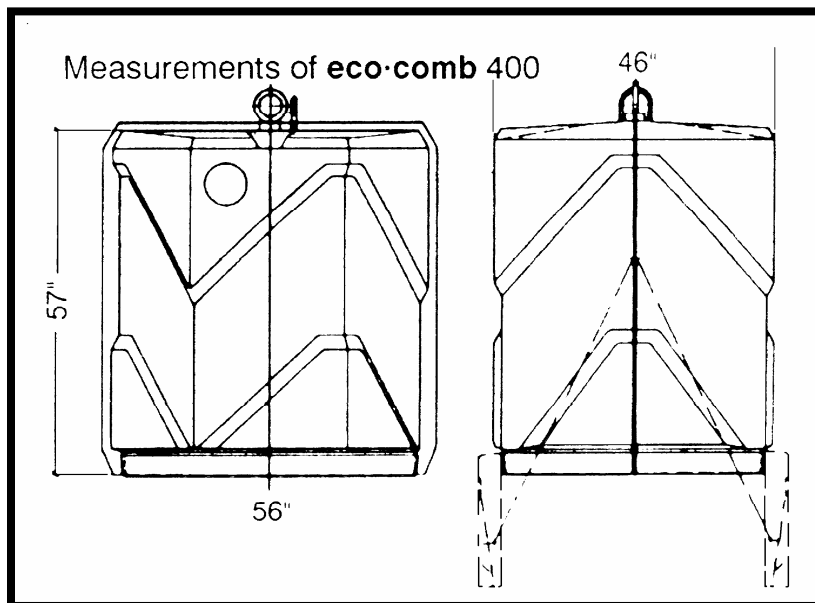

Capacity Tested: This container is tested for load capacities by filling with sand and then performing the container handling and discharge procedures.

Centralized discharge for spill-free loading of pick-up vehicle.

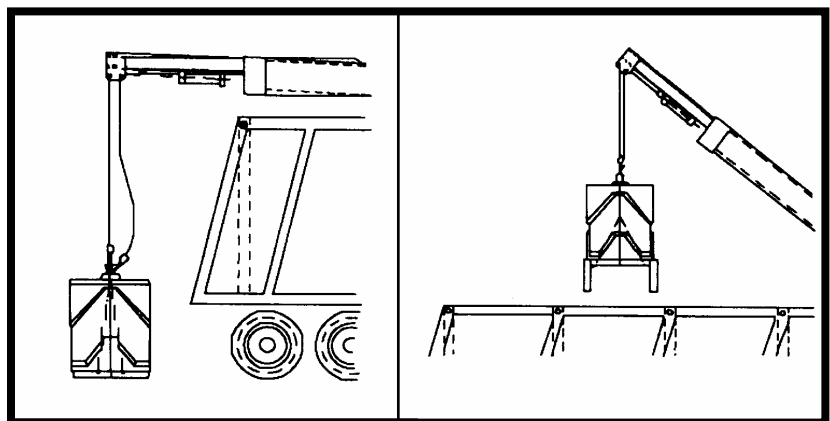
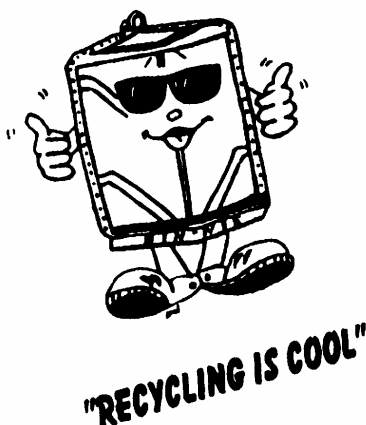

C. F. Maier Composites, Inc. • 500 E. Crystal • Lamar Colorado 81052
(800) 962-6079 • Fax: (719) 336-3091 • Email: mail@cfmaier.com